

DIMENSIONI TECNICHE

TECHNICAL DIMENSIONS | DIMENSIONES TÉCNICAS | DIMENSIONS TECHNIQUES |
ТЕХНИЧЕСКИЕ РАЗМЕРЫ

BASI SOPPESE

HANGING BASES
MUEBLES BAJOS SUSPENDIDOS
ELÉMENTS BAS SUSPENDUS
НАВЕСНЫЕ НИЖНИЕ ТУМБЫ

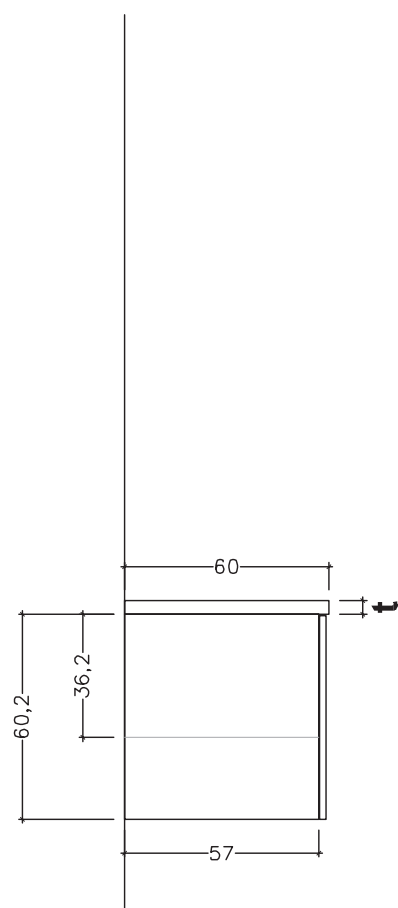

BASI / PENSILI

BASES / WALL UNITS
MUEBLES BAJOS / MUEBLES ALTOS
ELÉMENTS BAS / ELÉMENTS HAUTS
НАВЕСНЫЕ ВЕРХНИЕ ШКАФЫ

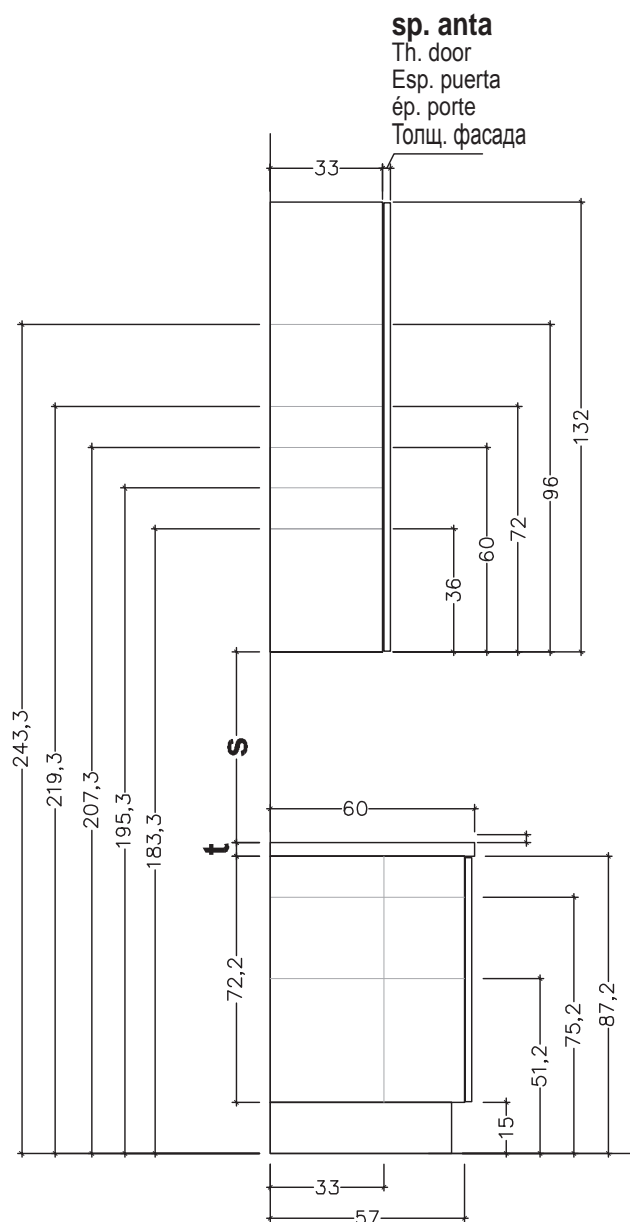

sp. anta
Th. door
Esp. puerta
ép. porte
Толщ. фасада

COLONNE

VERTICAL UNITS
COLUMNAS
COLONNES
ШКАФЫ-ПЕНАЛЫ

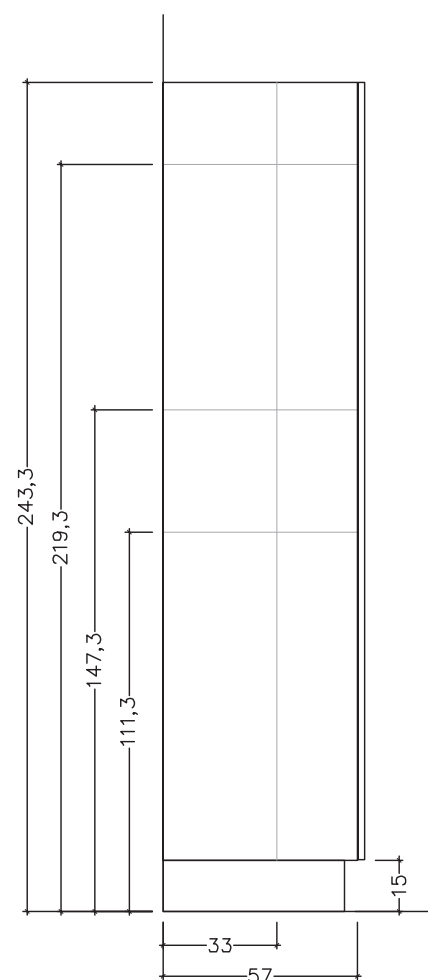

t = (cm)	s = (cm)
2	58.1
3	57.1
4	56.1
6	54.1
10	50.1

t = la misura della piana varia da cm 2 fino a cm 10

s = la misura varia in base all'altezza della piana

t = the size of the top surface varies from 2 cm to 10 cm
s = the size varies in accordance with the height of the top surface

t = la medida de la encimera varía entre 2 y 10 cm
s = la medida varía según la altura de la encimera

t = la mesure du plateau varie de 2 cm jusqu'à 10 cm
s = la mesure varie selon la hauteur du plateau

t = размер топа варьирует от 2 до 10 см
s = размер варьирует в зависимости от толщины топа

COMPONIBILITÀ MODULI A GIORNO

MODULARITY OF OPEN SHELVING MODULES | MODULARIDAD MÓDULOS ABIERTOS |
 POSSIBILITÉ D'AGENCEMENT DES MODULES OUVERTS | КОНФИГУРАЦИИ ОТКРЫТЫХ МОДУЛЕЙ

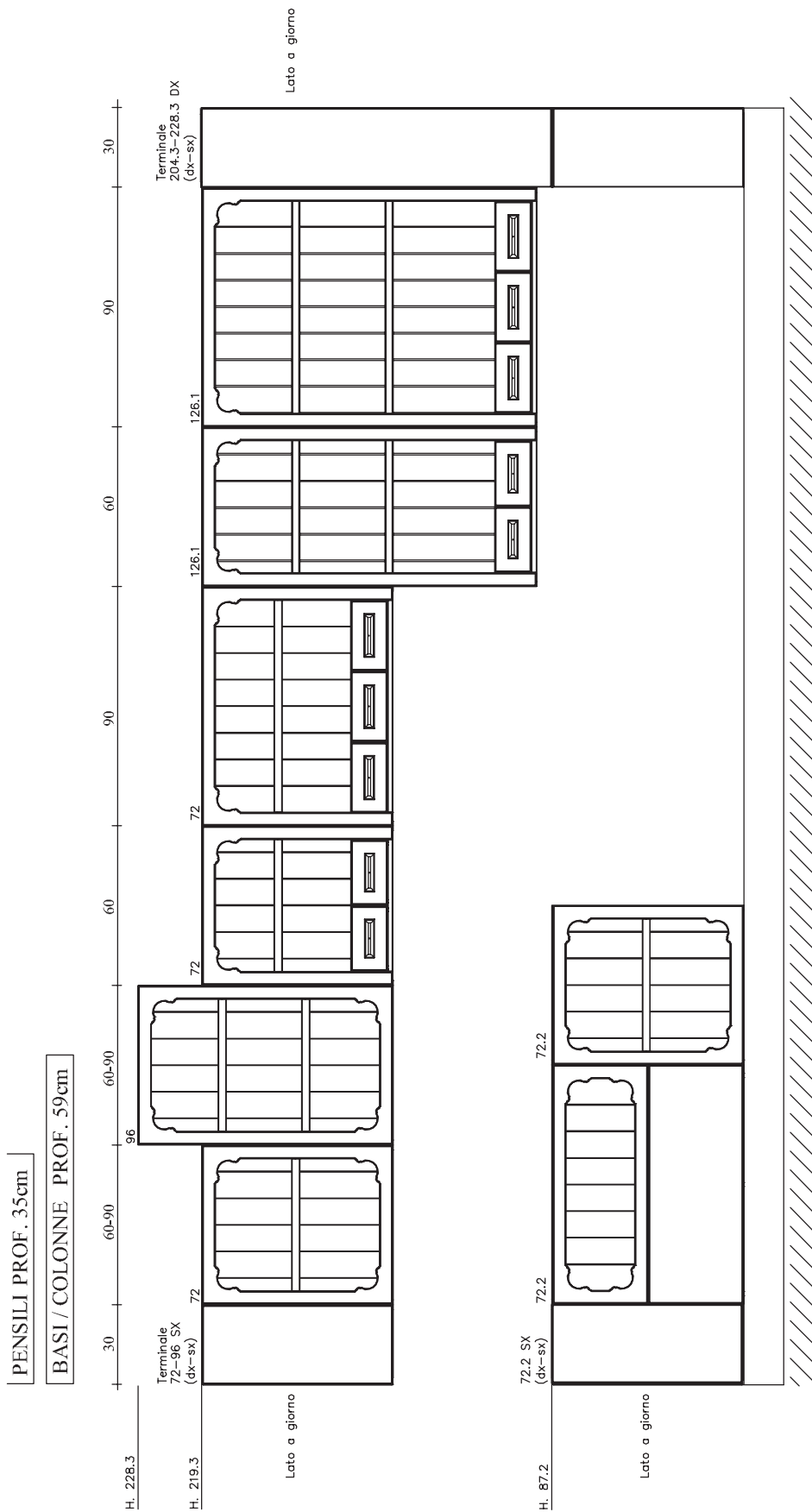

COMPONIBILITÀ PENSILI

MODULAR CABINETS | MODULARIDAD DE LOS MUEBLES ALTOS |

POSSIBILITE D'AGENCEMENT DES ELEMENTS HAUTS | СОЧЕТАЕМОСТЬ НАВЕСНЫХ ШКАФОВ

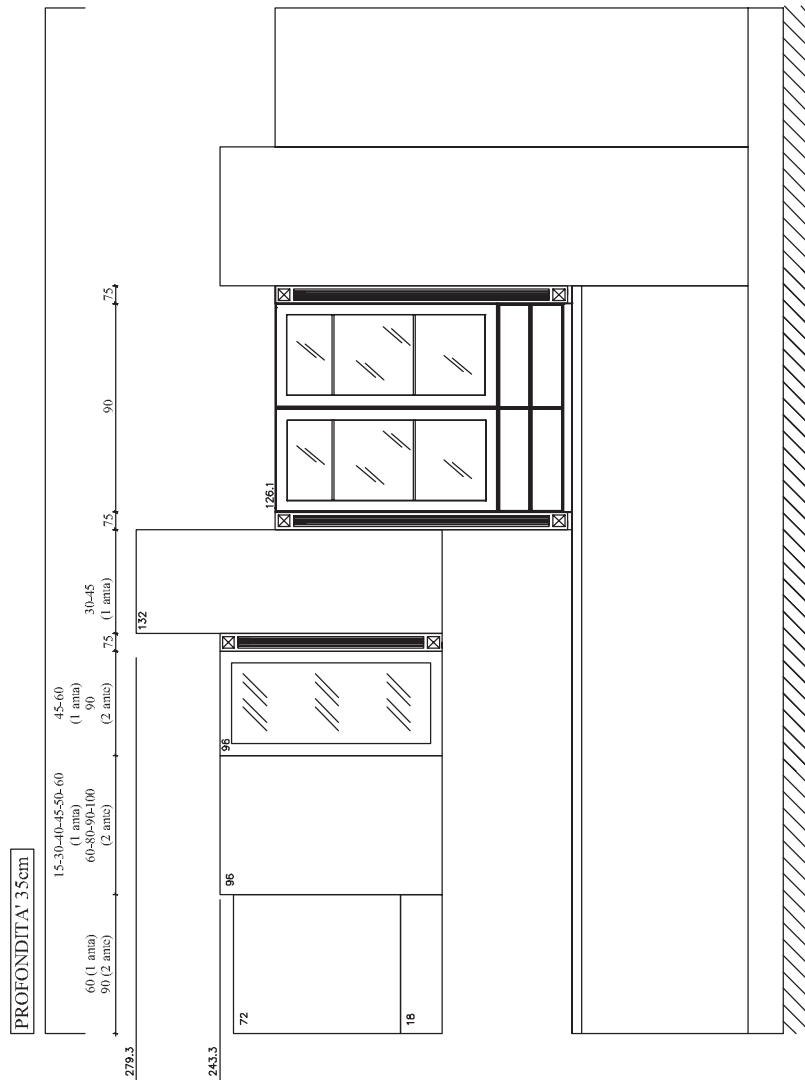
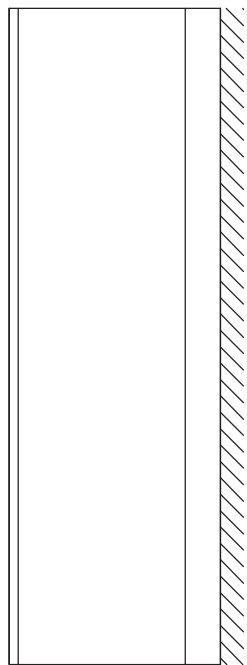
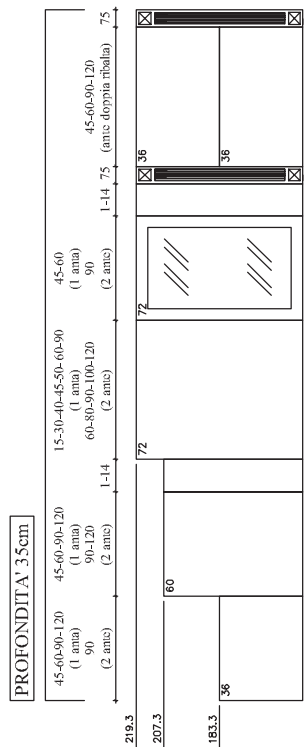

COMPONIBILITÀ BASI

MODULAR BASES | MODULARIDAD DE LOS MUEBLES BAJOS |

POSSIBILITE D'AGENCEMENT DES ELEMENTS BAS | СОЧЕТАЕМОСТЬ НАПОЛЬНЫХ ШКАФОВ

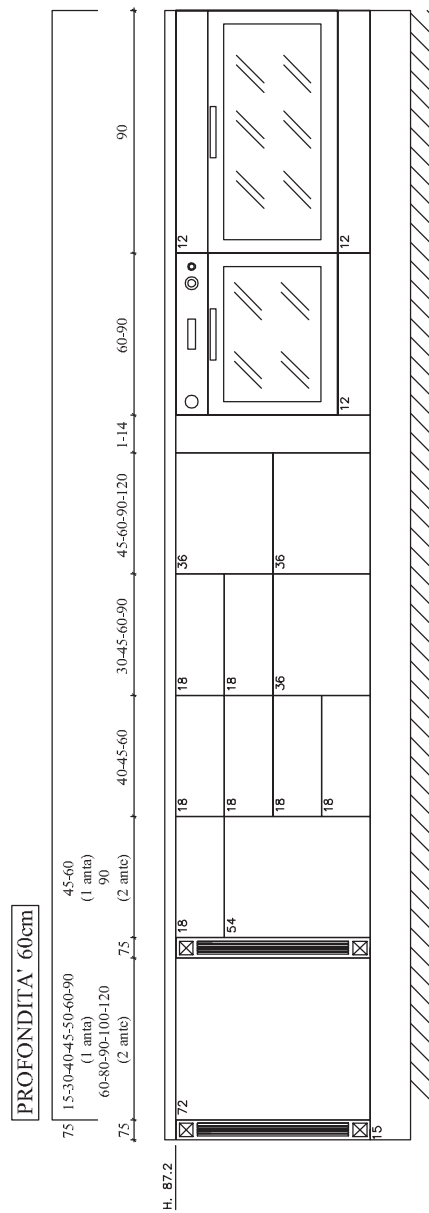
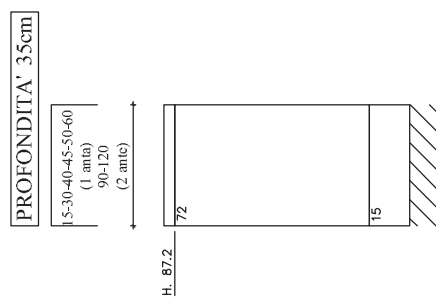
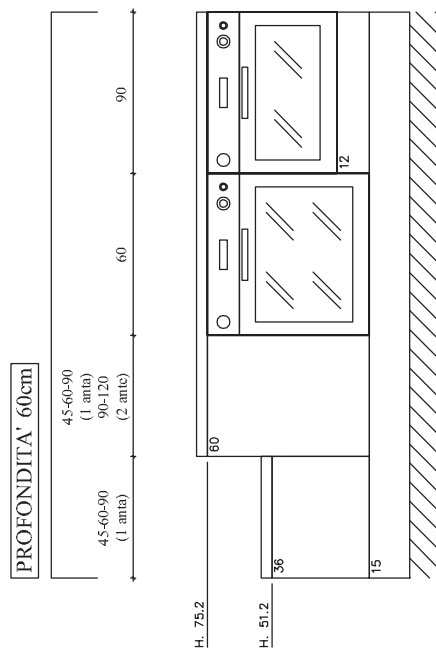
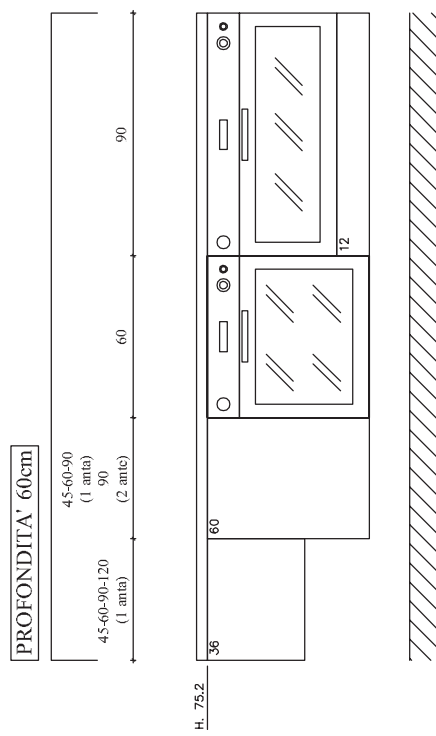

COMPONIBILITÀ COLONNE FORNO

MODULAR UPRIGHT OVEN UNITS | MODULARIDAD DE LAS COLUMNAS HORNO |

POSSIBILITE D'AGENCEMENT DES COLONNES FOUR |

СОЧЕТАЕМОСТЬ ШКАФОВ-ПЕНАЛОВ ПОД ДУХОВОЙ ШКАФ

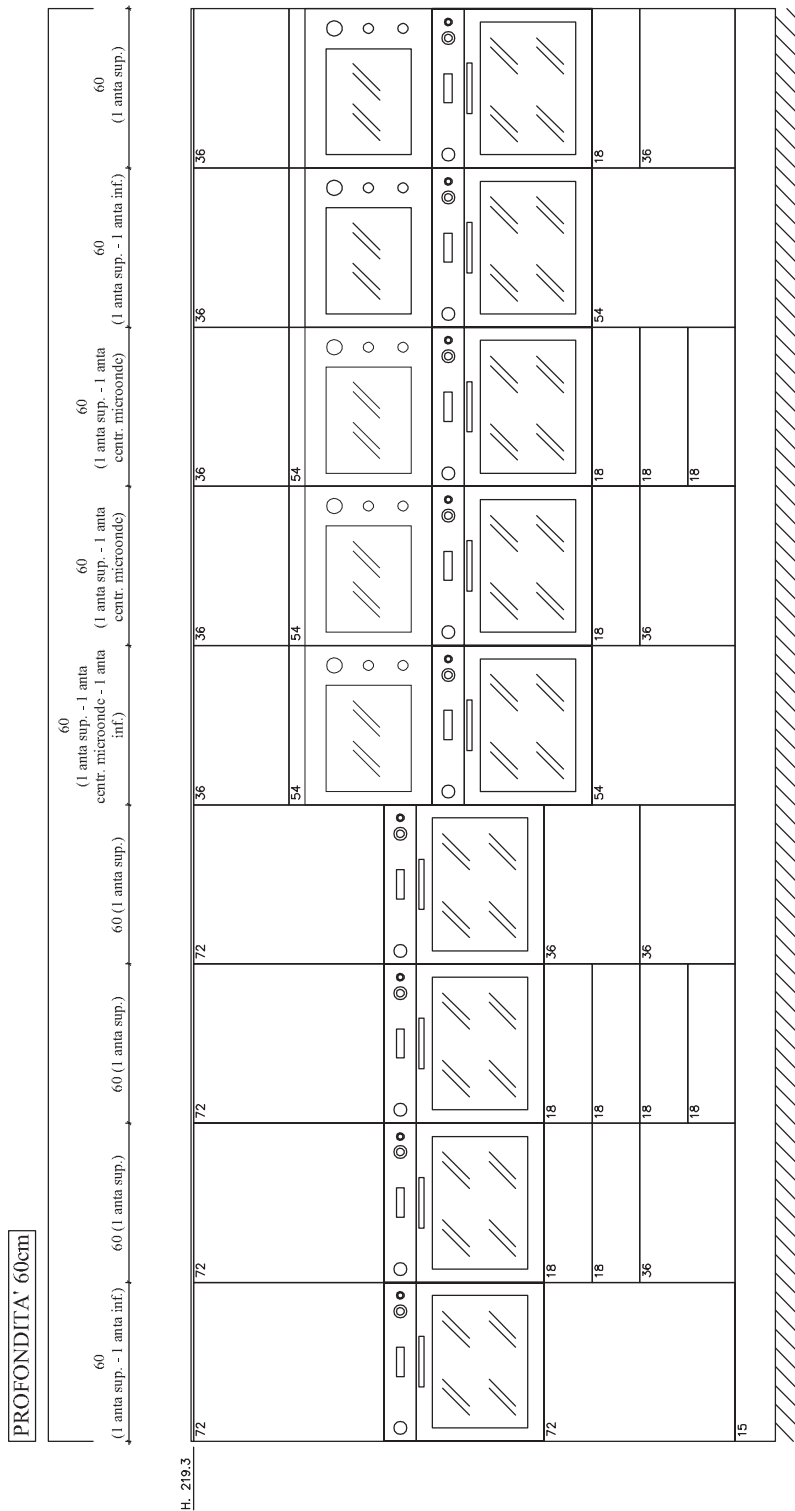
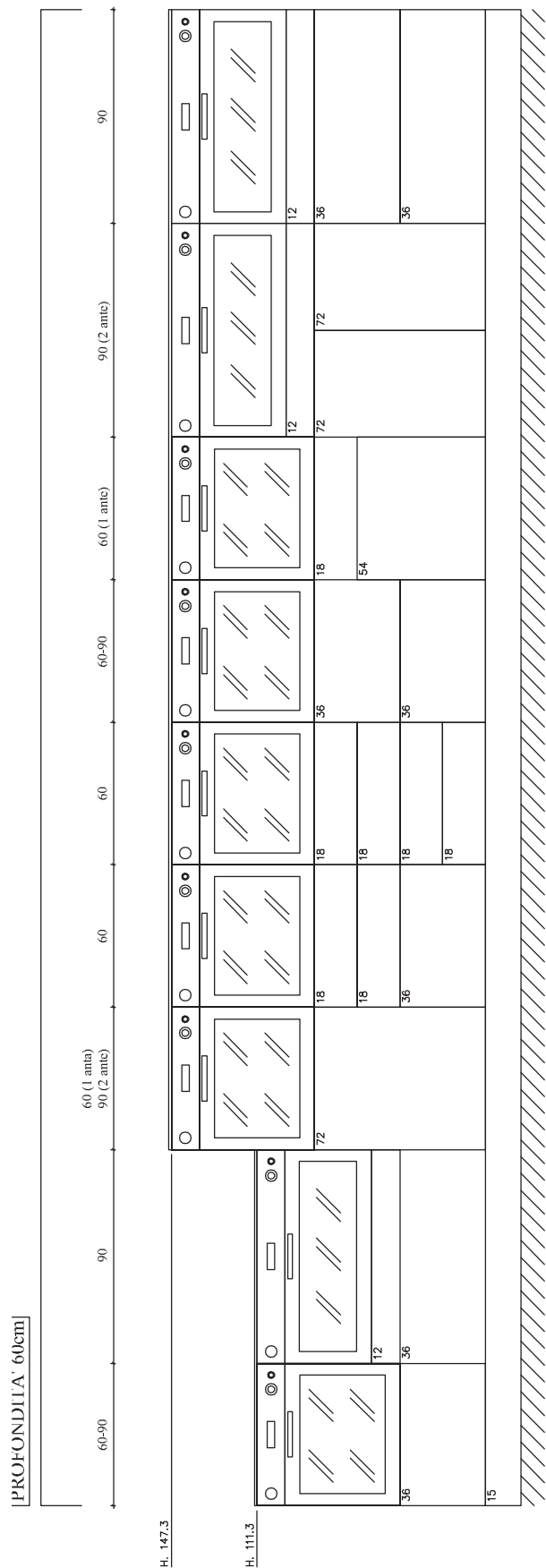

COMPONIBILITÀ COLONNE FORNO

MODULAR UPRIGHT OVEN UNITS | MODULARIDAD DE LAS COLUMNAS HORNO |
 POSSIBILITE D'AGENCEMENT DES COLONNES FOUR |
 СОЧЕТАЕМОСТЬ ШКАФОВ-ПЕНАЛОВ ПОД ДУХОВОЙ ШКАФ

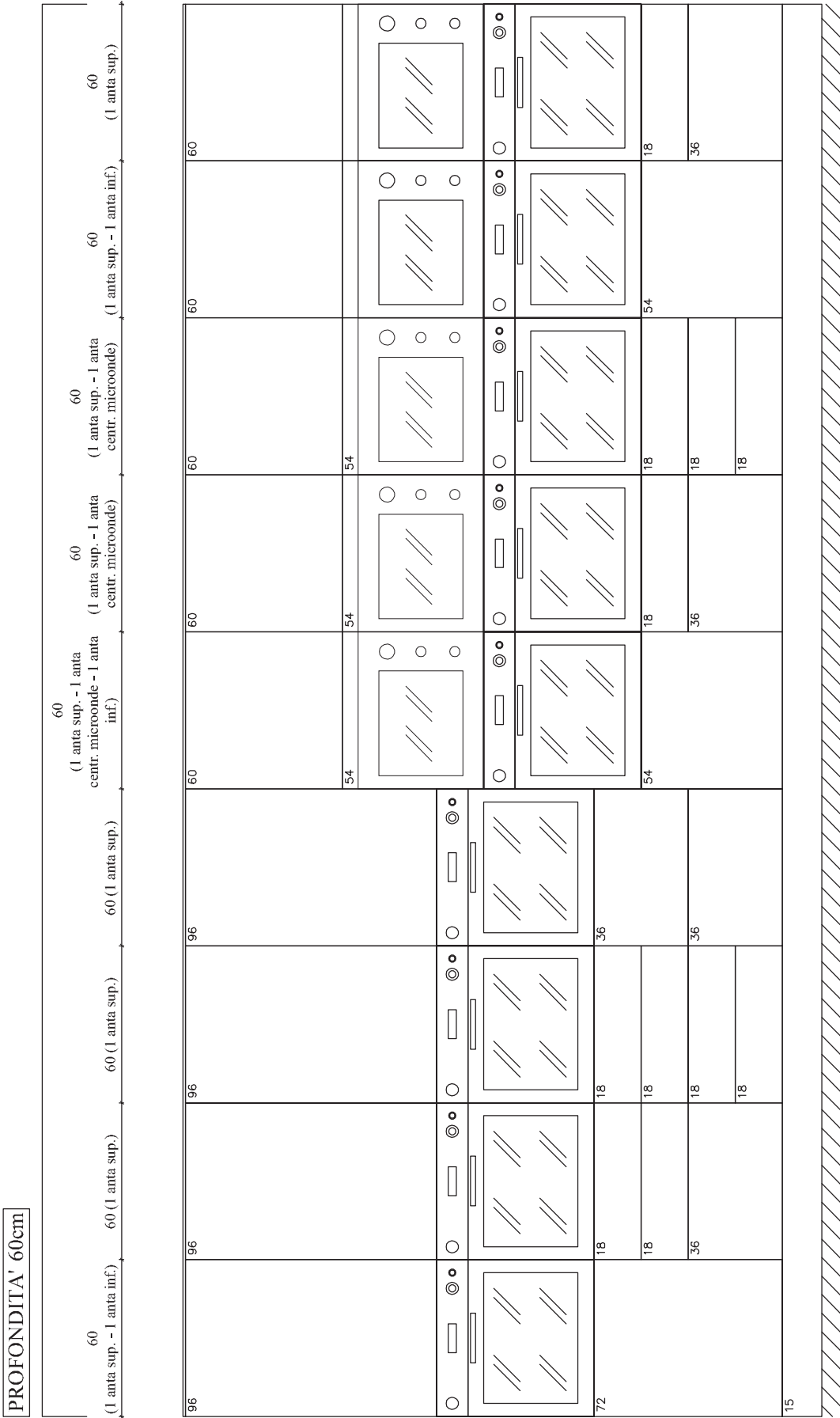

13

COMPONIBILITÀ COLONNE

VERTICAL UNITS MODULARITY | COMPONIBILIDÀ COLUMNS |
ÉLÉMENTS DES COLONNES | ΚΟΜΠΟΘΕΤΑ ΚΟΛΟΝΝΗ

